

PLAN VIEW

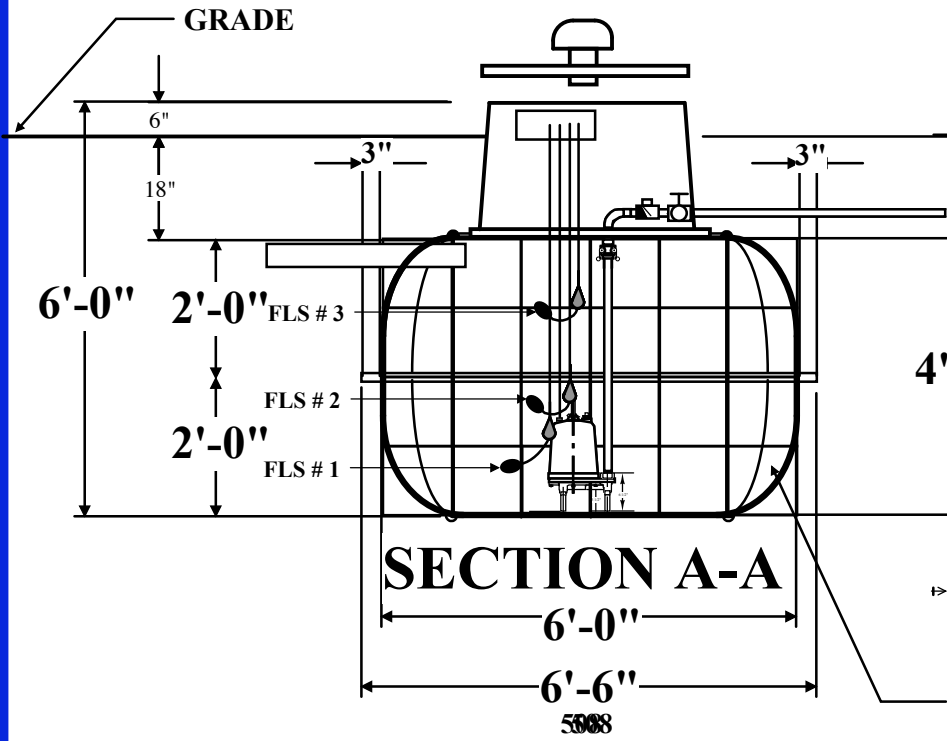

SECTION A-A

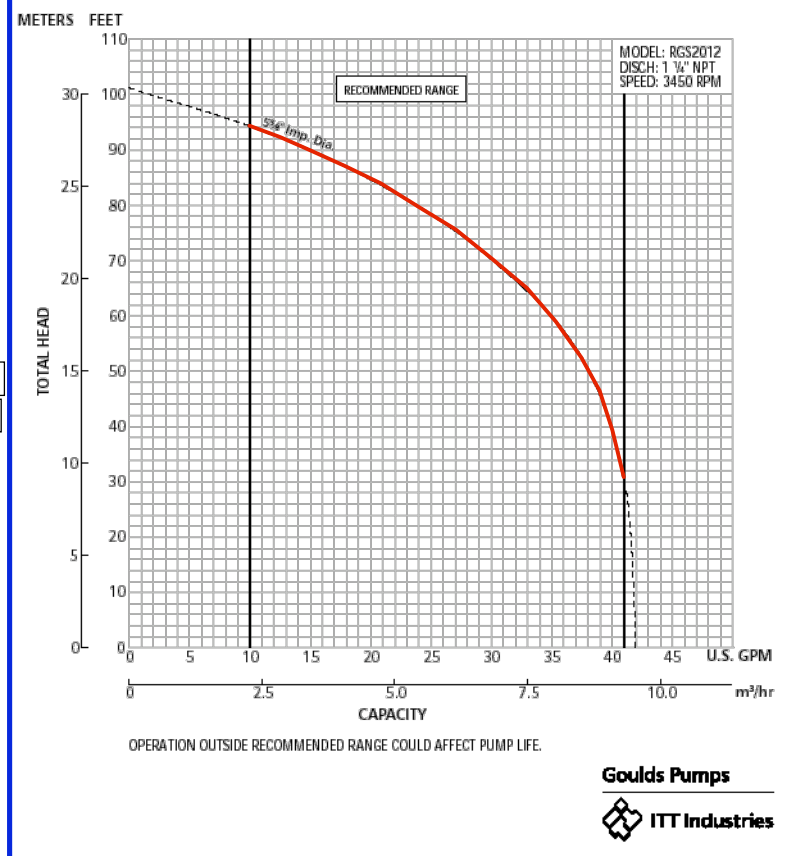
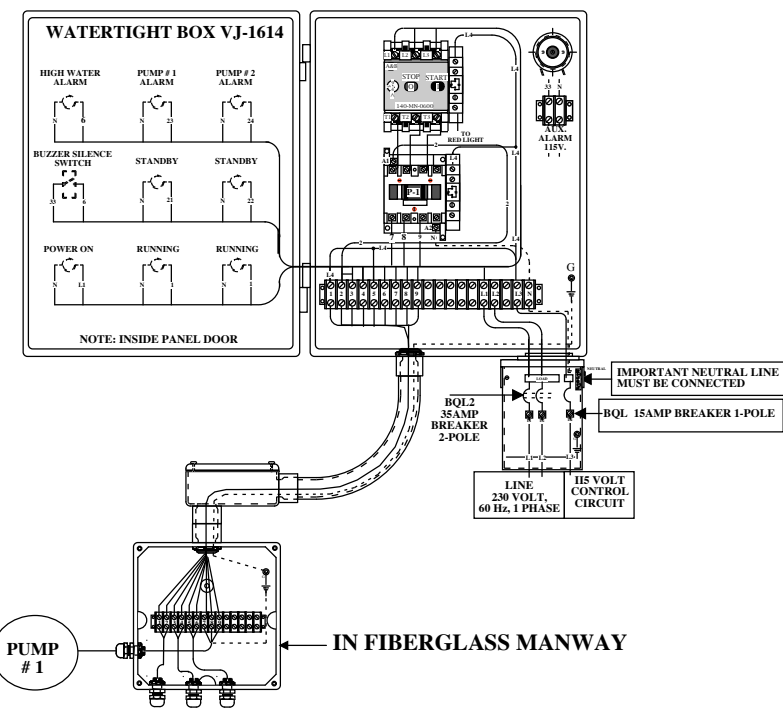
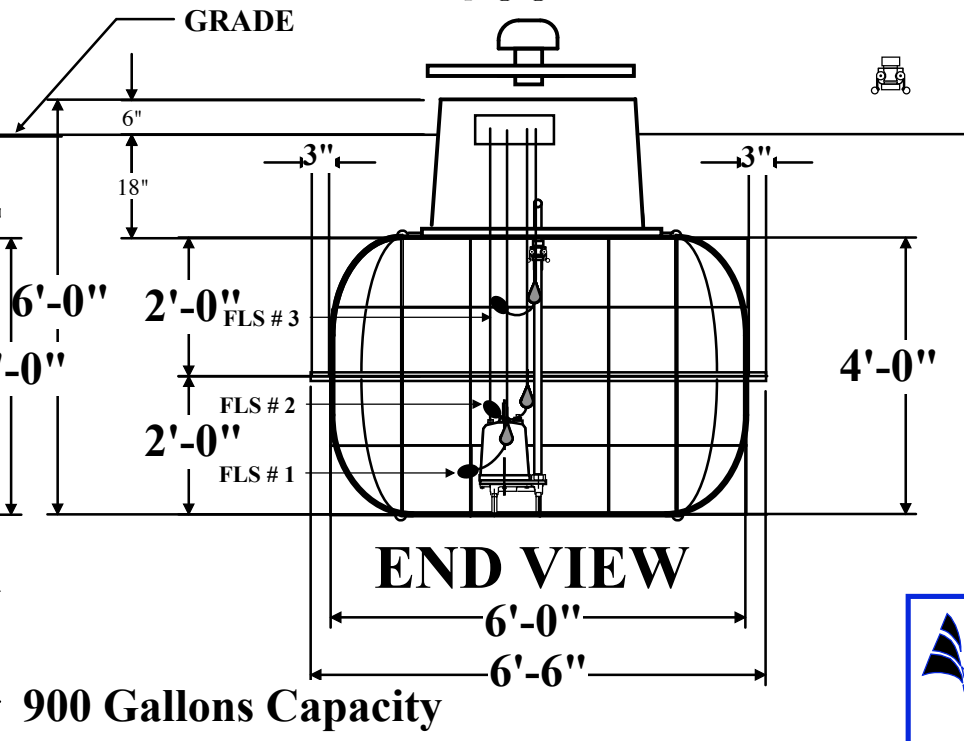

END VIEW

900 Gallons Capacity

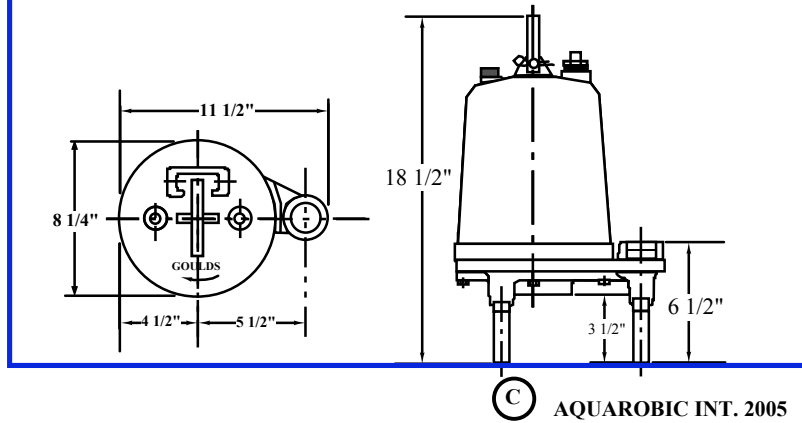

© AQUAROBIC INT. 2005

NOTES FOR AQUAROBIC'S GRINDING PUMP LIFT STATION:

1. THE CONCEPT HEREIN DISCLOSED IS PROPRIETARY WITH AQUAROBIC INTERNATIONAL INC. AND MAY NOT BE REPRODUCED OR USED WITHOUT PRIOR WRITTEN AUTHORIZATION.
2. FLS # 1 LOW WATER SHUT OFF SWITCH, TURNS PUMP OFF.
3. FLS # 2 TURNS PUMP ON
4. FLS # 3 HIGH WATER ALARM SWITCH, TURNS RED LIGHT AND ALARM BELL ON
5. EFFLUENT GRINDING PUMP: GOULDS MODEL # RGS2012 230VOLTS, SINGLE PHASE, 60 HERTZ, 2 HP. 15.3 AMPS (40 GL./MIN. AT 20' LIFT.)
6. THE FIBERGLASS TANK HAS A 900 GALLONS CAPACITY

AQUAROBIC[®]
INTERNATIONAL INC.
 206 Wyck Street,
 Winchester, Virginia U.S.A 22601
 PHONE: (540) 667-9991 / FAX: (540) 667-9427
 Web: <http://www.aquarobicinternational.com>

SCALE: N.T.S. BY: D.E. PAVON

**SIMPLEX GRINDING PUMP LIFT STATION IN
 900 GALLON CAPACITY
 AQUAROBIC 6' X 6' X 4' FIBERGLASS TANK**

DRAWING NO: 1346-2145 DATE : 09 / 20 / 2005