

30" Round by 24" tall Manway s

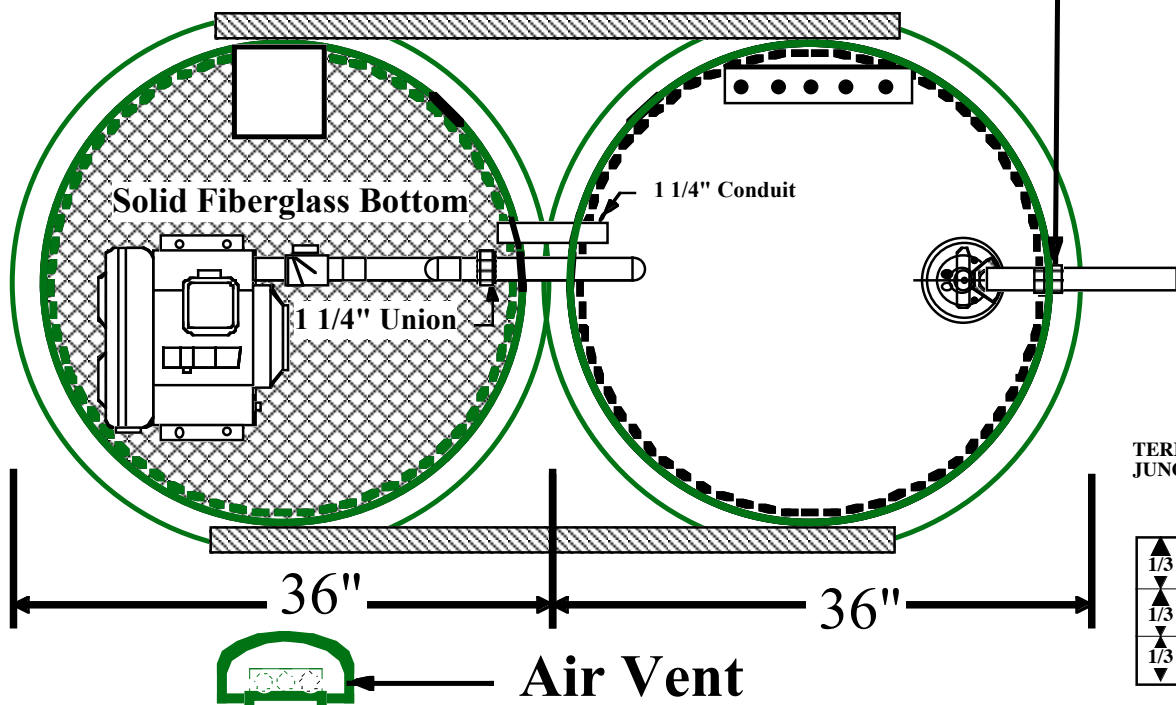

1 1/2" Thru Hull Water Tight Fitting

OMRON H5L WEEKLY TIMER

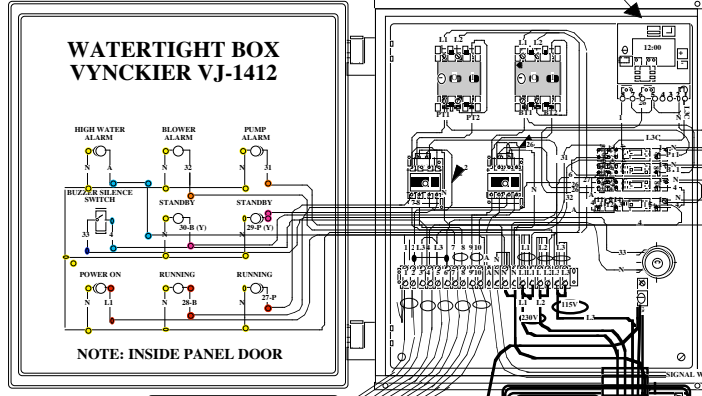

THE AQUAROBIC REMOTE LATCHING REMOTE ALARM
 THE RED LIGHT WILL STAY ON UNTIL THE SERVICE PROVIDER TURNS IT OFF MANUALLY
 THE HOME OWNER CAN SILENCE THE BUZZER MANUALLY BY TURNING OFF THE SWITCH
 THE ALARM WILL RESPOND TO:
 HIGH WATER,
 PUMP ON OVERLOAD,
 BLOWER ON OVERLOAD,

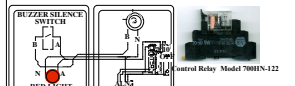

SEPARATE POWER SUPPLY FOR ALARM CIRCUIT

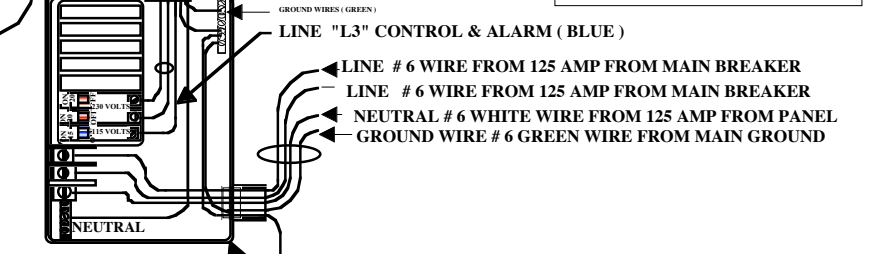
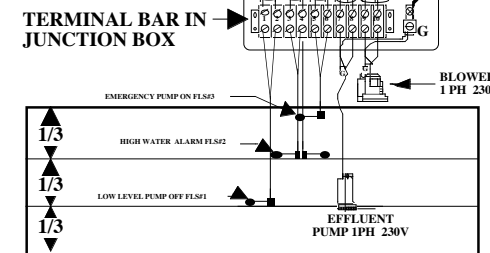

SUB FEED DISTRIBUTION PANEL FOR SYSTEM FROM A 125 AMPS BREAKER IN HOUSE SERVICE PANEL

Junction Box

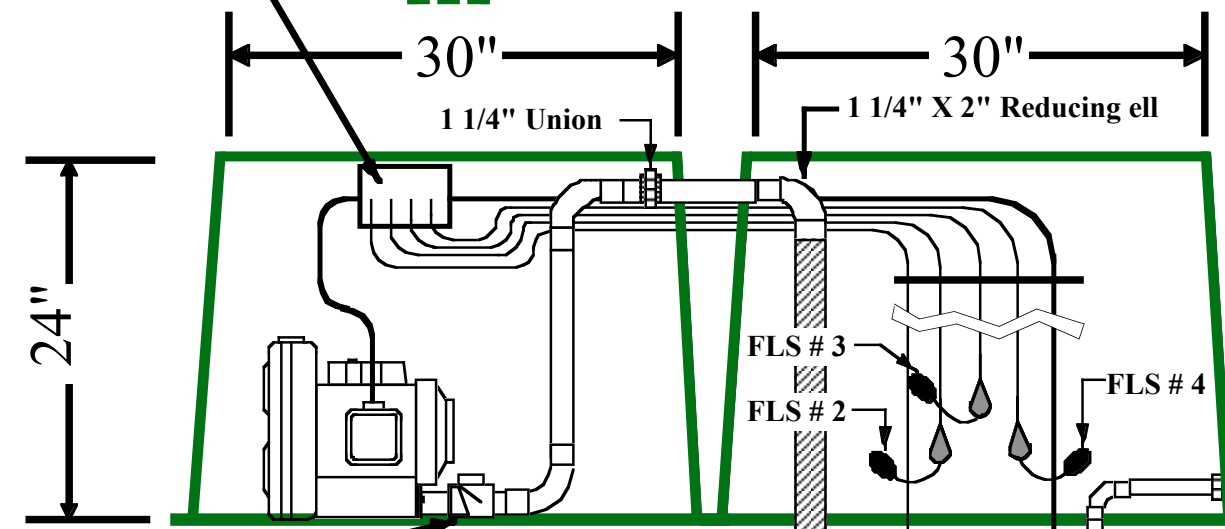

6' GROUNDING ROD

1 1/2" Cam lock for Pump Hose

1 1/2" Thru Hull Water Tight Fitting

8 = AIR DIFFUSER ASSEMBLY

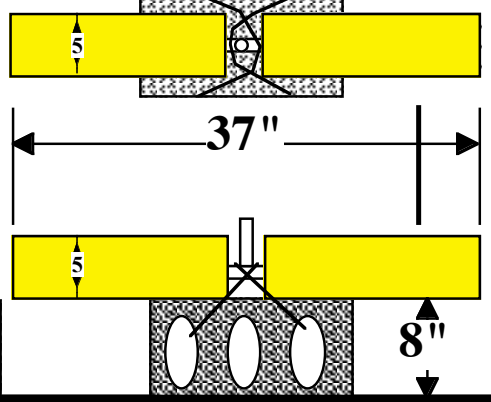
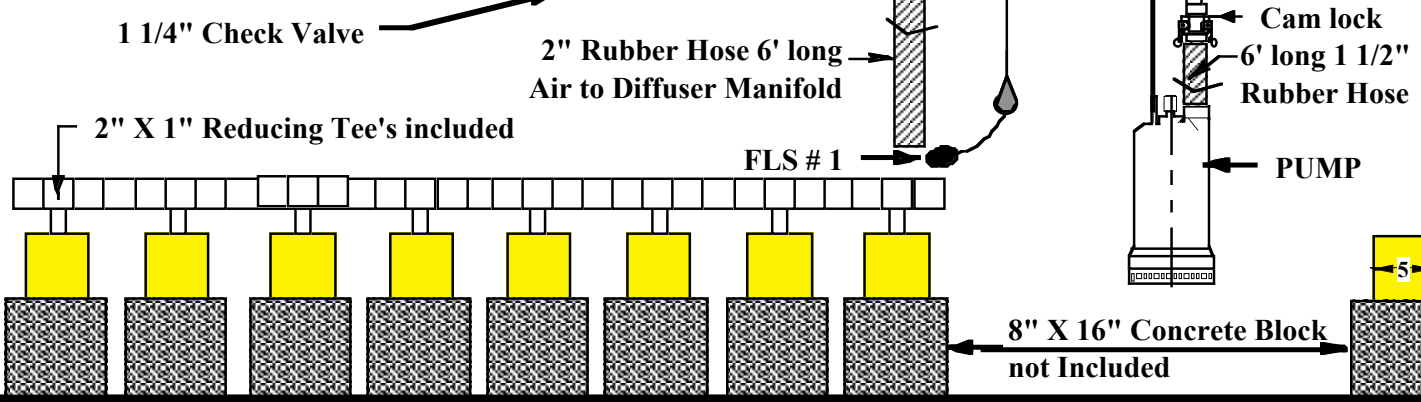

© Aquarobic International, Inc. 2005

AQUAROBIC®
 INTERNATIONAL, INC.
 206 Wyck Street, Suite 100, Winchester, Virginia, USA. 22601
 1-800-927-8304
 E. Mail: Dan@aquarobicinternational.com
 Phone: (540) 667-9991 / Fax: (540) 667-9427
 Web Page: <http://www.aquarobicinternational.com>

Scale : N.T.S. 54291- -230V By: D. E. Pavón

THE MINI-PLANT KIT SYSTEM FOR CONCRETE TANKS MOUNTING

Drawing # 5805-2005K May 11, 2005